

AUDITORIUM ORCHESTRA OPTIONS

Perkins&Will

OCT 10, 2019

OPTION 1: NO PIT - CURRENT DESIGN



OPTION 2: PIT WITH NO INFILL

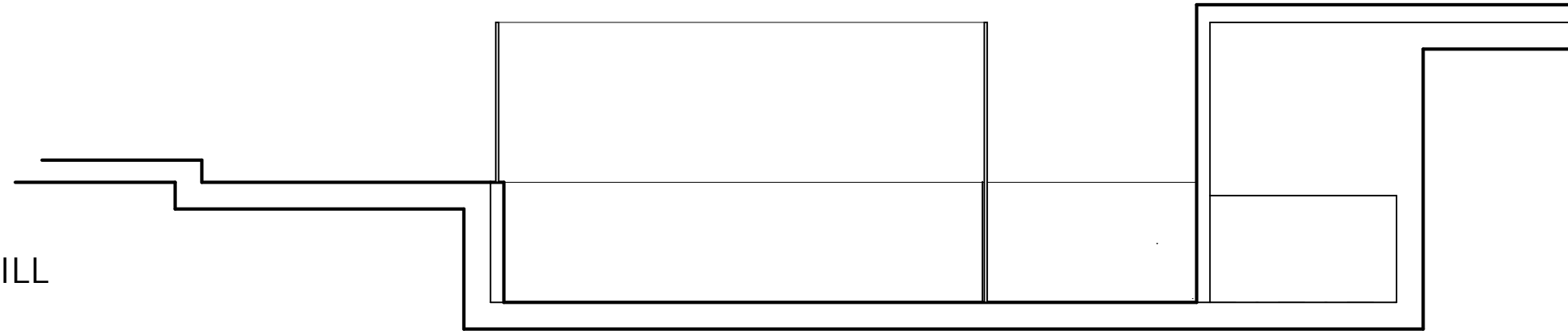

OPTION 3: PIT WITH TEMPORARY FLOOR INFILLS

-3A - TEMPORARY RAMP & STAIR (shown)

-3B - LIFT & STAIR

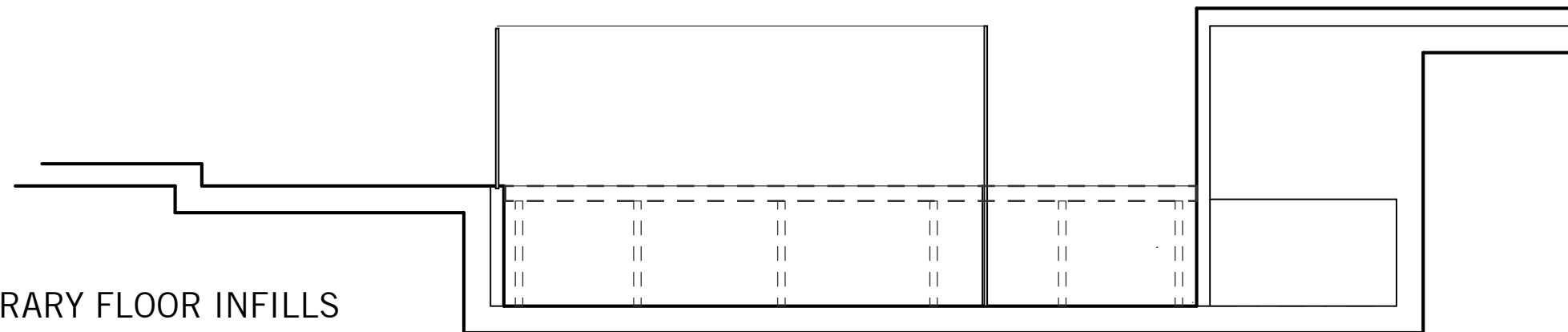

OPTION 4: MECHANICAL PIT & LIFT

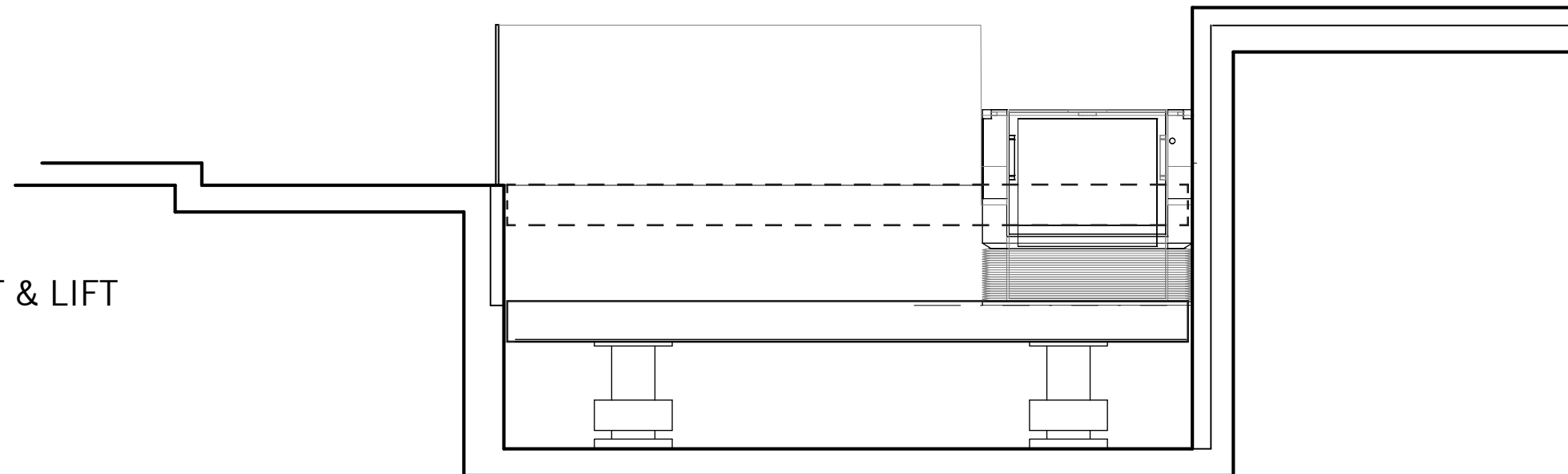

ORCHESTRA OPTION 1: NO PIT (CURRENT DESIGN)

Perkins&Will

OCT 10, 2019

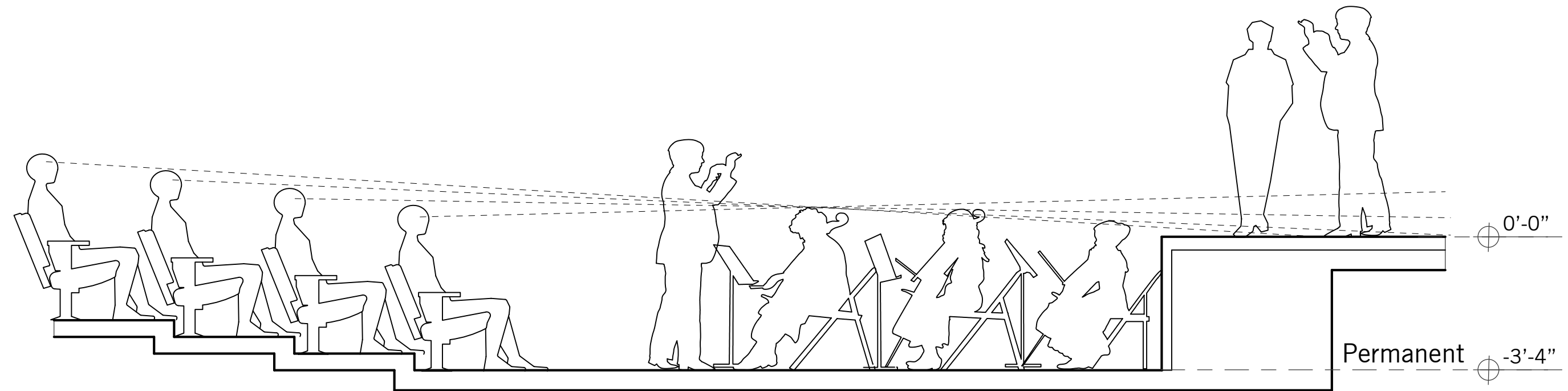
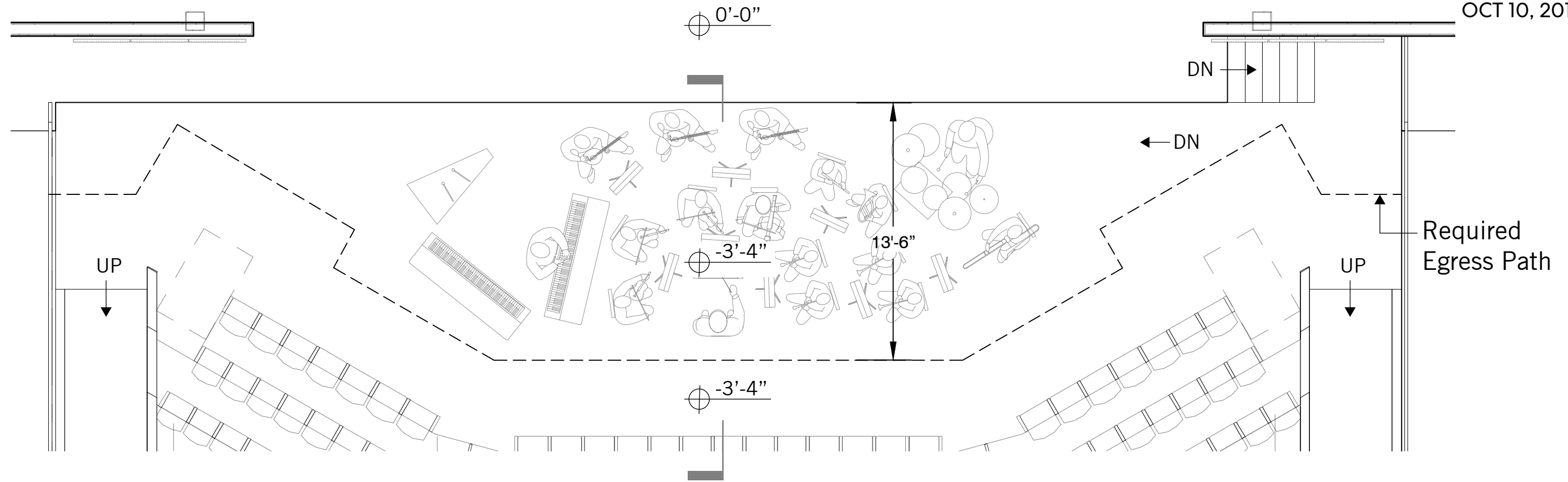

ORCHESTRA OPTION 2: PIT WITH NO INFILL (TEMPORARY RAMP SHOWN; LIFT ALSO OK)

Perkins&Will

OCT 10, 2019

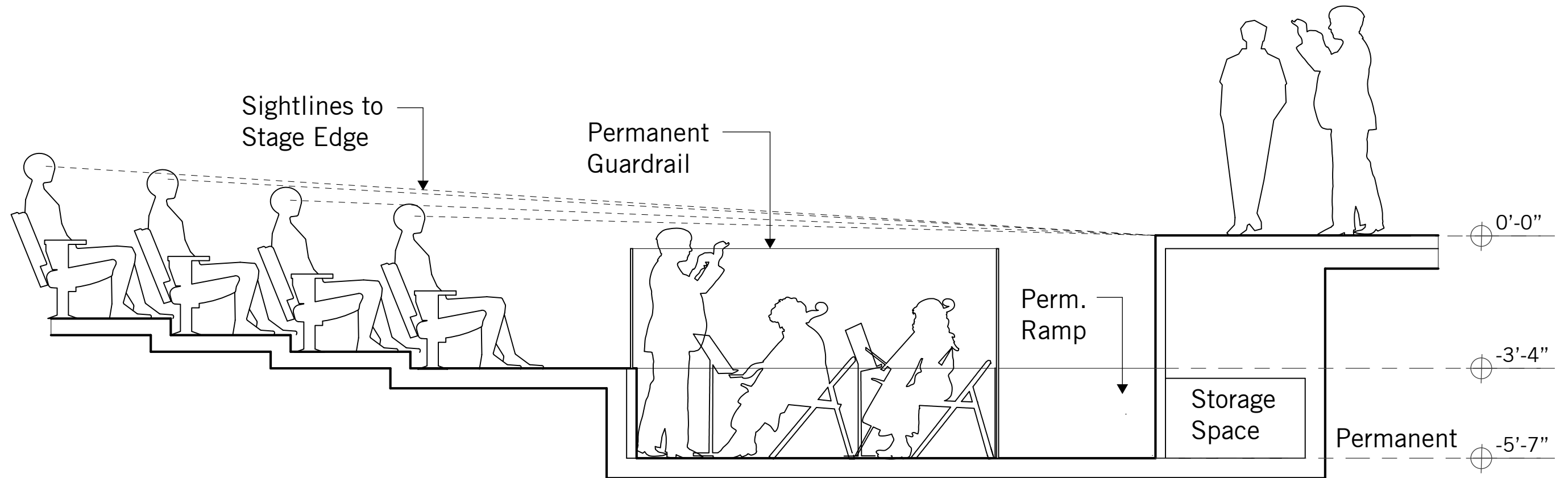
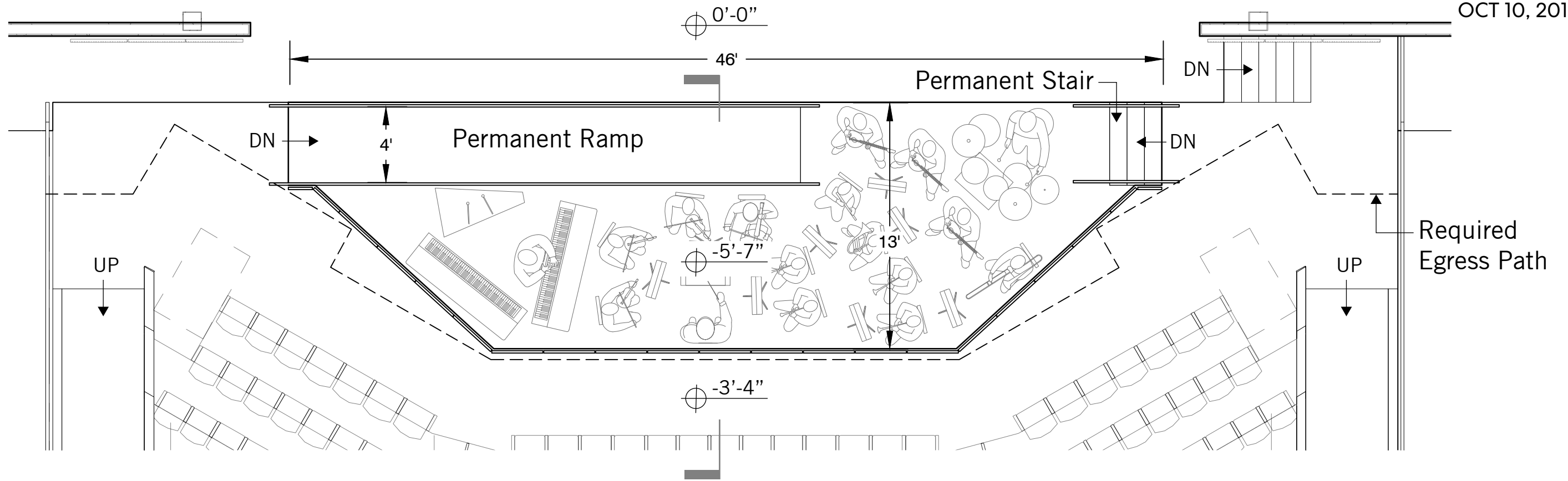

ORCHESTRA OPTION 3A: PIT WITH MANUAL INFILL PANELS & TEMPORARY RAMP

Perkins&Will

OCT 10, 2019

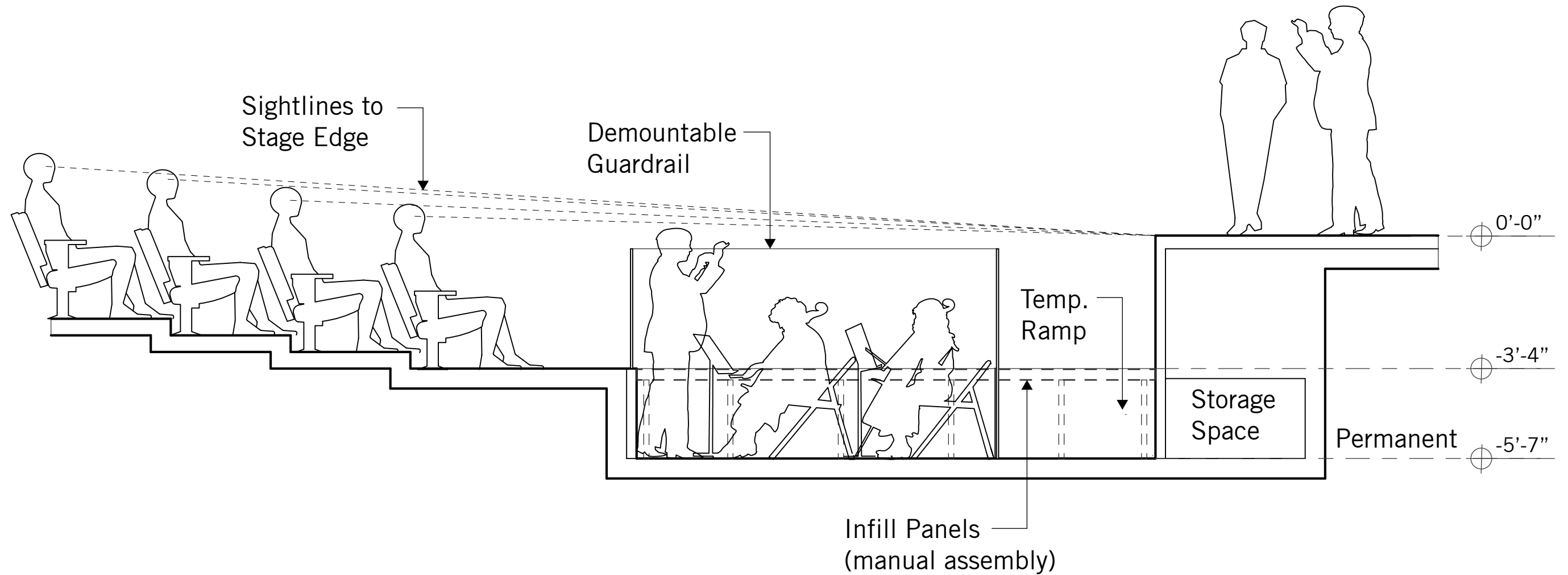
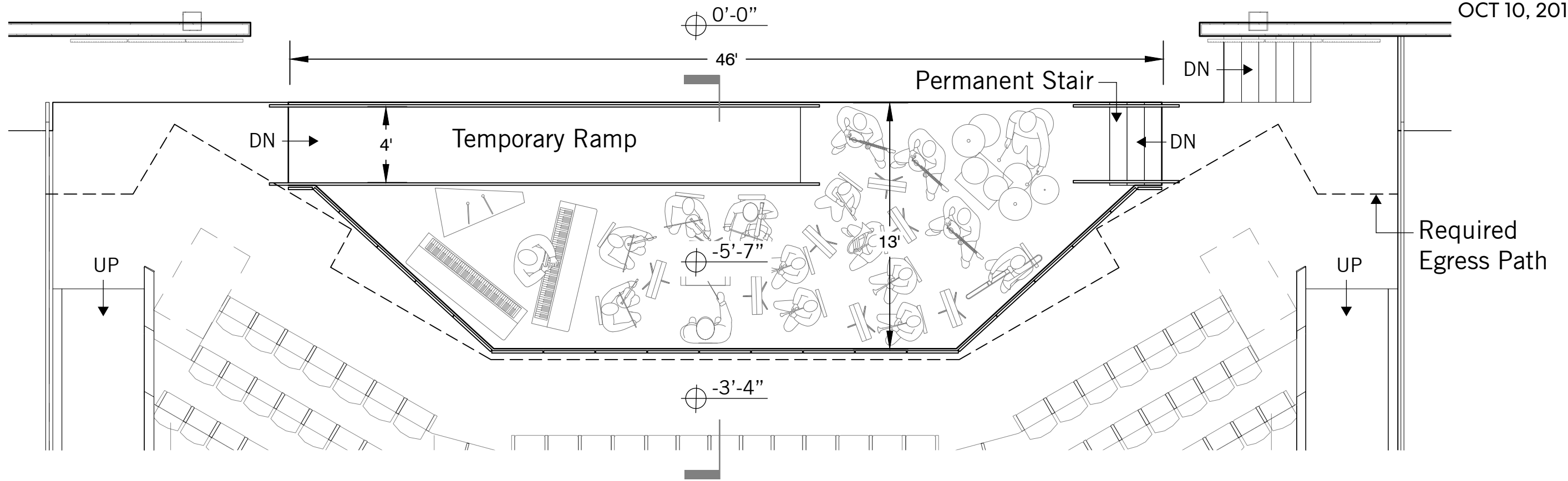

ORCHESTRA OPTION 3B: PIT WITH MANUAL INFILL PANELS & LIFT

Perkins&Will

OCT 10, 2019

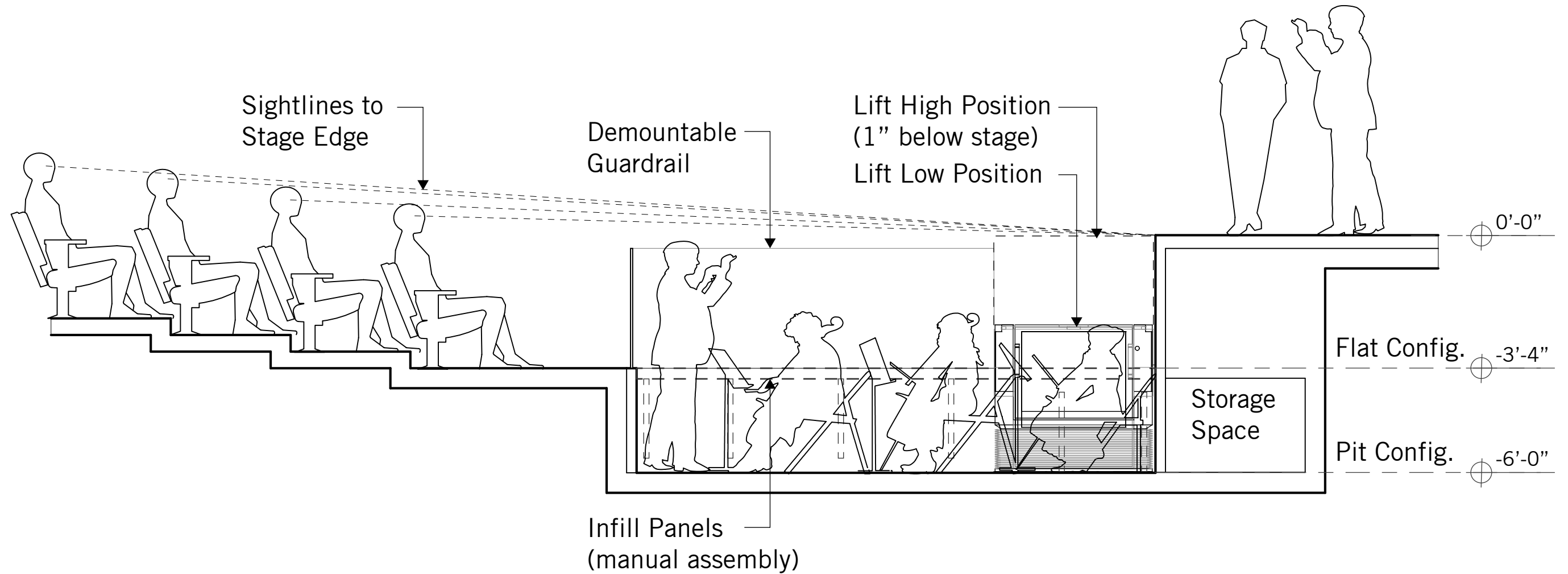
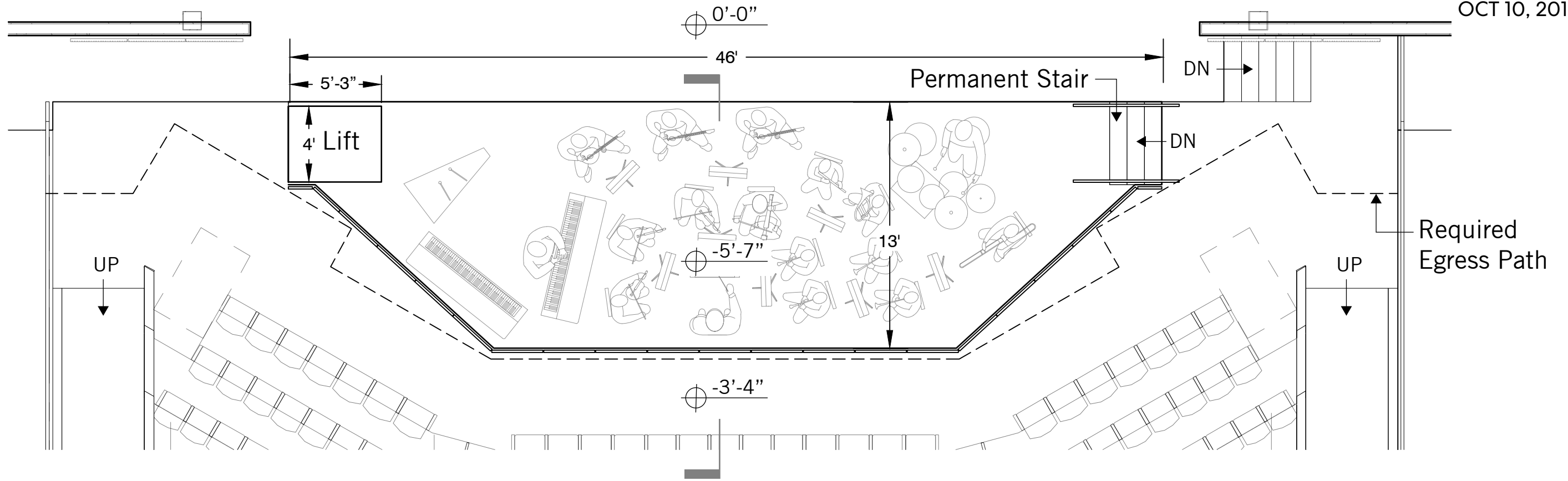

ORCHESTRA OPTION 4: MECHANICAL PIT WITH LIFT

Perkins&Will

OCT 10, 2019

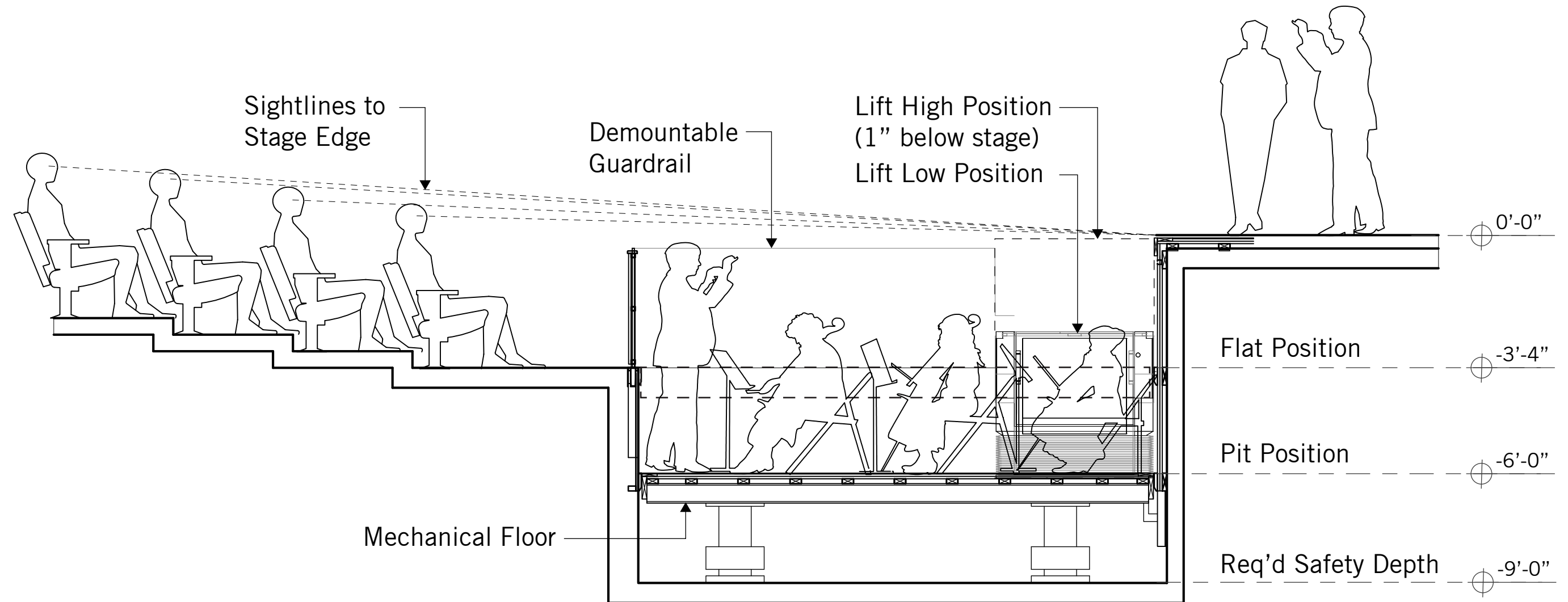
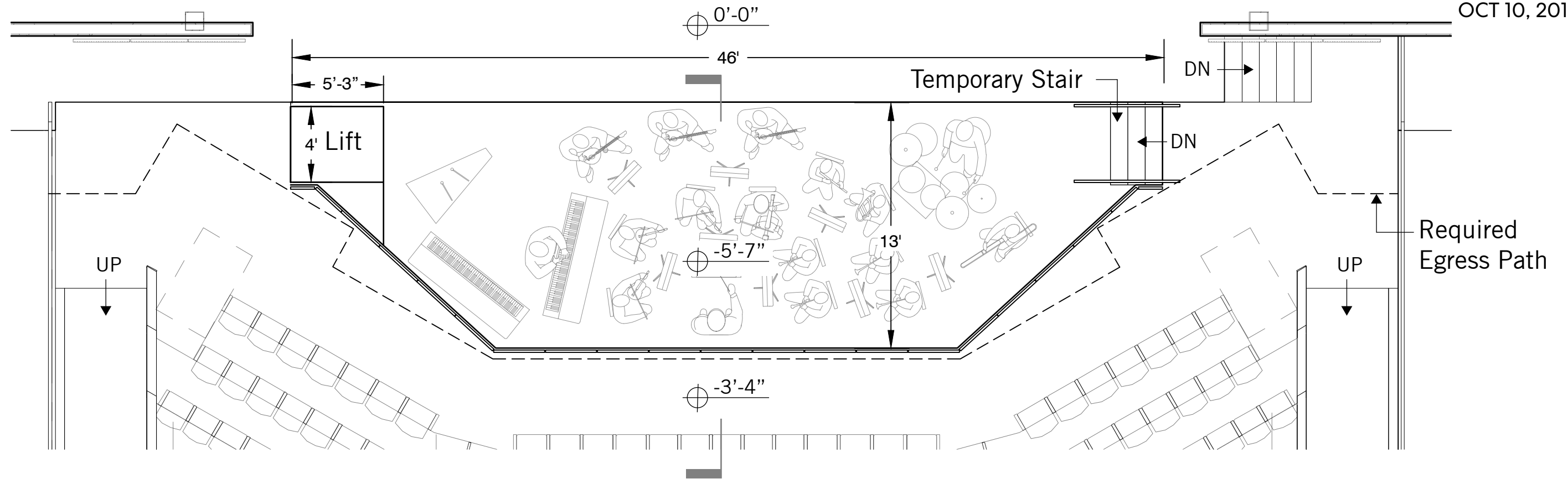

BELMONT MIDDLE AND HIGH SCHOOL AUDITORIUM
AUDIENCE ENVIROMENT

