

BELMONT HIGH SCHOOL BUILDING COMMITTEE MEETING

DECEMBER 19 2018



CURRENT - LEVEL 02 FLOOR PLAN

DECEMBER 19, 2018



CURRENT - LEVEL 04 FLOOR PLAN

DECEMBER 19, 2018

POND TERRACE CANOPY

FACADE DESIGN





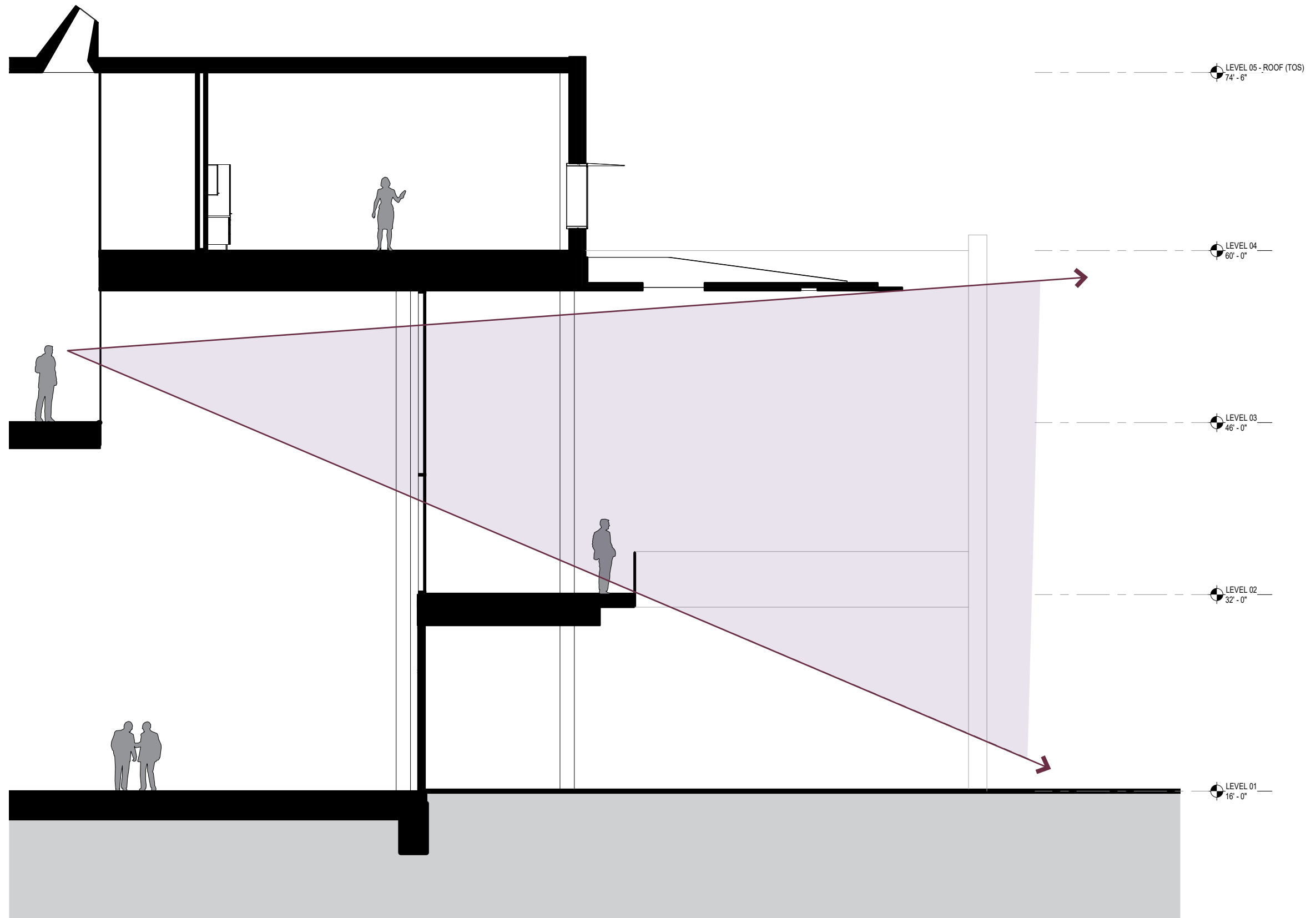

VIEW CORRIDOR - SCHEME 01

DECEMBER 19, 2018

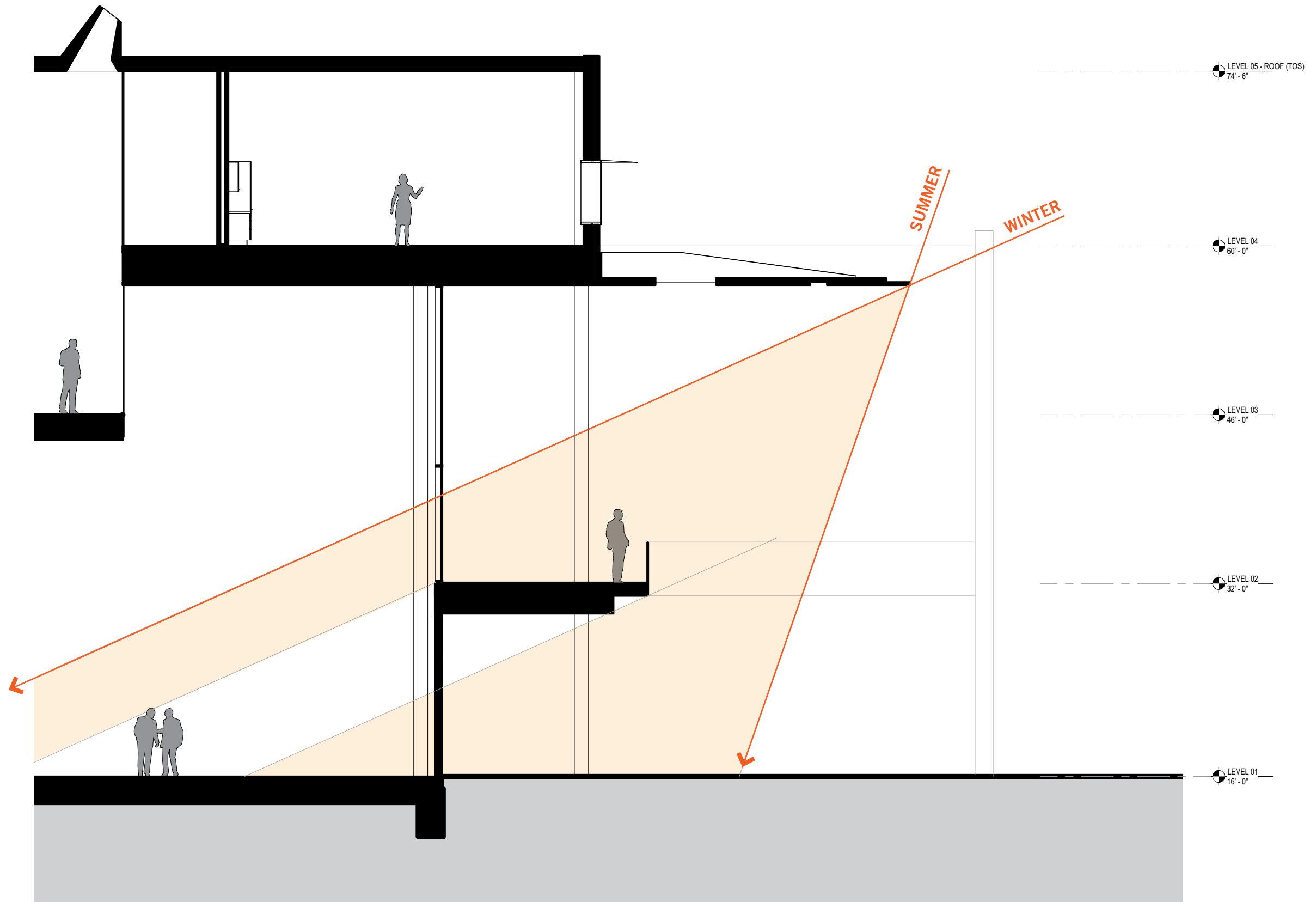

SUN ANGLES - SCHEME 01

DECEMBER 19, 2018



BUILDING ELEVATIONS

FACADE DESIGN

PERKINS+WILL



FACADE STUDY - WEST ELEVATION



FACADE STUDY - NORTH ELEVATION

BRICK

FACADE DESIGN

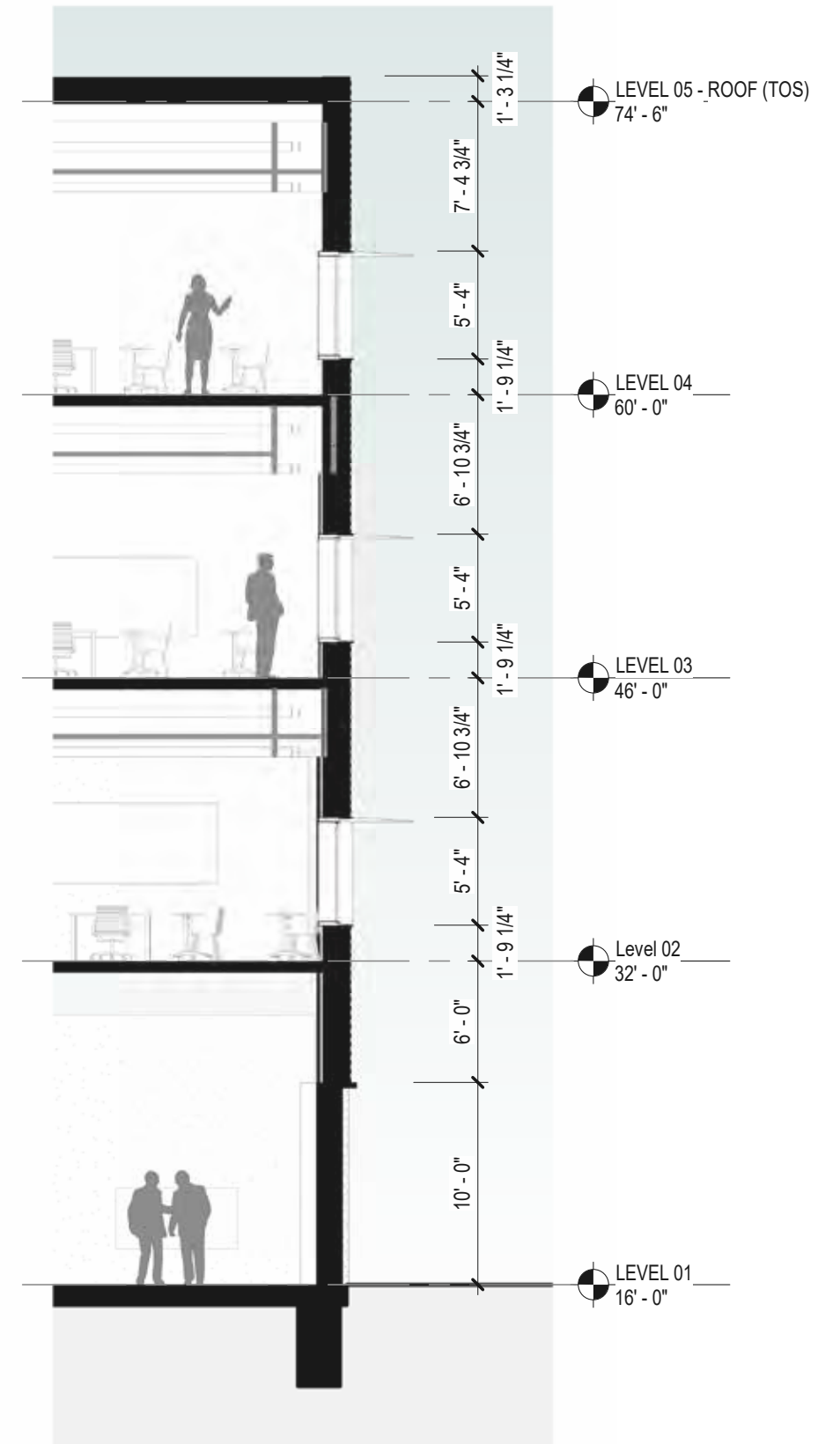

BRICK WALL - SW ACADEMIC WING

DECEMBER 19, 2018

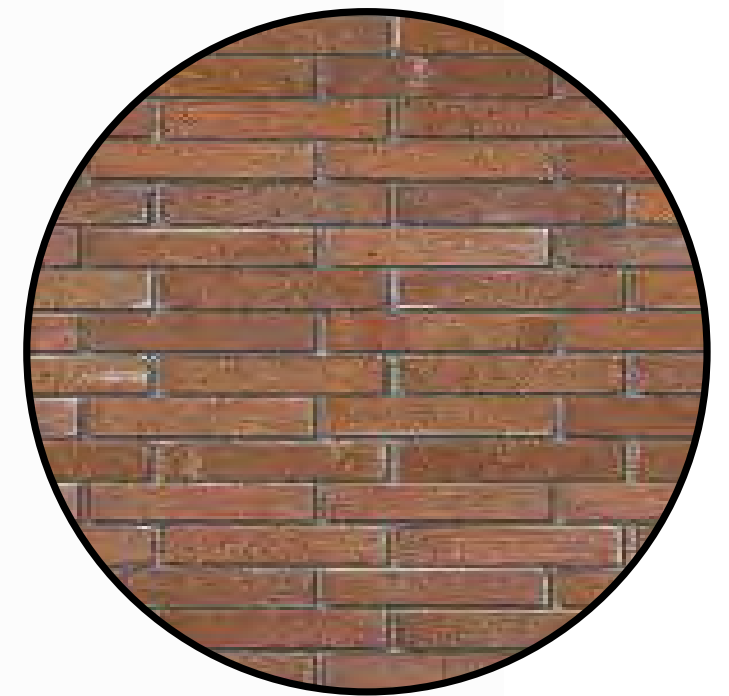
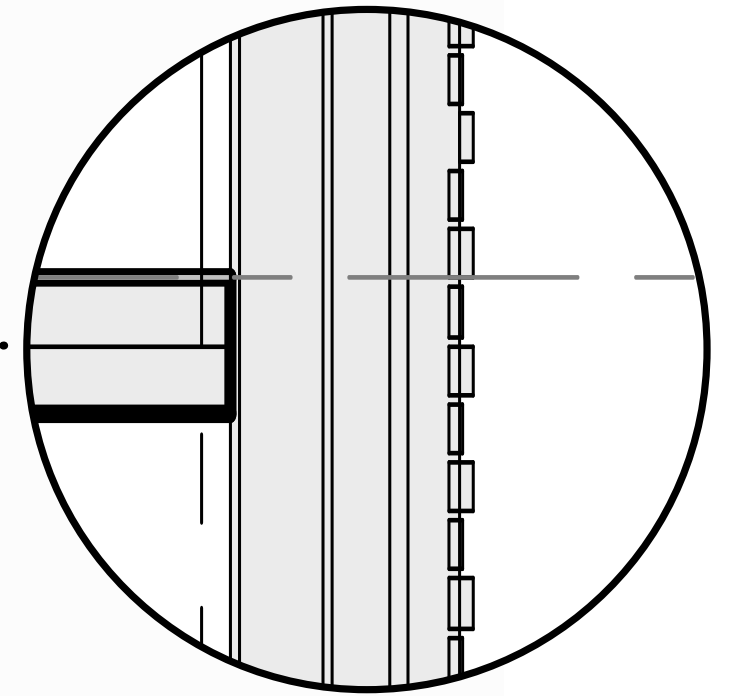

BRICK WALL - SW ACADEMIC WING

DECEMBER 19, 2018

